

**TO-263 SMD Power Resistors – STR35 Series**

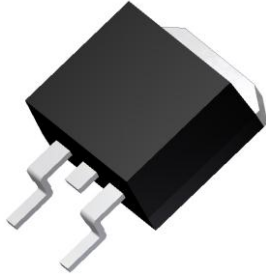

**■ Features**

- 35 watts at 25°C case temperature
- TO-263 style power package for surface mounted resistor
- Molded case for protection
- Resistor is electrically isolated from metal tab

**■ Applications**

- Switching Power Supplies
- Snubbers Circuits
- Automated Machine Controller
- RF Power Amplifiers
- Low Energy Pulse Loading
- UPS
- Voltage Regulation
- Bleeder Resistors

**■ Construction**

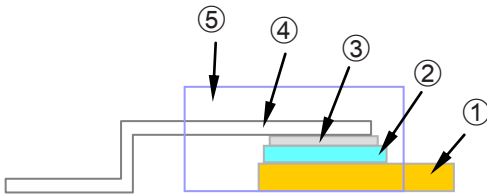

① Flange	④ Lead
② Alumina Substrate	⑤ Molding
③ Resistor Layer	

**■ Dimensions**

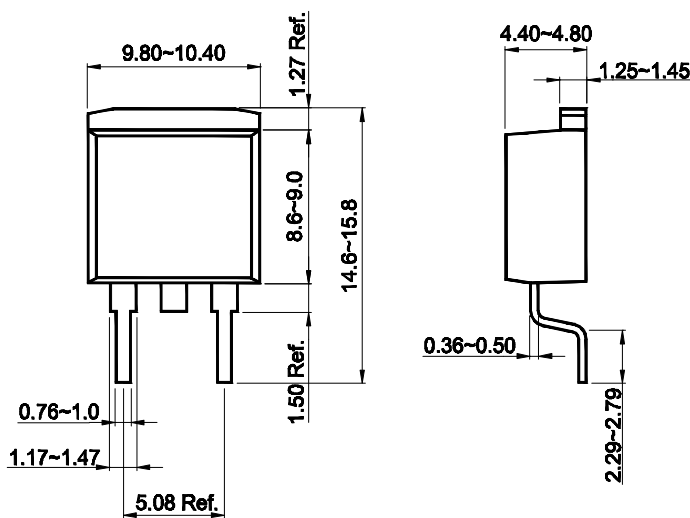

**■ Derating Curve**

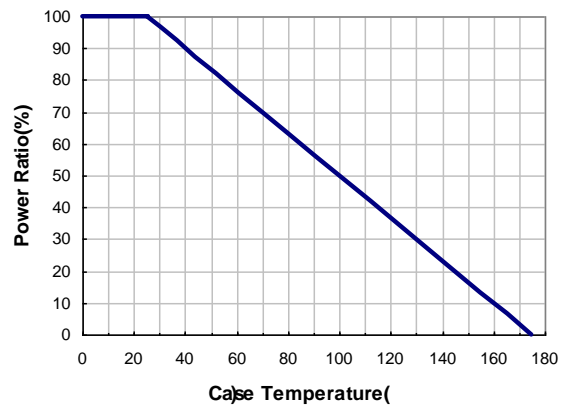

Type	Weight (g)
STR35	1.5g

**Part Numbering**

STR	35	J	B	D	1001
Product Type	Power	Resistance Tolerance	Packaging Code	TCR (PPM/°C)	Resistance
	35: 35 Watts	D: ±0.5% F: ±1% J: ±5% K: ±10%	T: Taping D: Tube	D: ±50 E: ±100 F: ±200 G: ±300 - : No Specified	R500: 0.5Ω 0100: 10Ω 4700: 470Ω 1001: 1KΩ 1002: 10KΩ

**Electrical Characteristics Specifications**

Item	Resistance Range				TCR (PPM/°C)
	±0.5%	±1%	±5%	±10%	
STR35	0.5Ω - 0.91Ω				No Specified
	1Ω - 2.7Ω				±100 ±300
	3Ω - 10Ω				±100 ±200
	>10Ω - 100KΩ				±50 ±100 ±200

- Operating Voltage: 500V Max.
- Dielectric Strength: 2000VAC
- Insulation Resistance: 10GΩ min.
- Working Temperature Range: -55°C to +175°C
- Resistance Value < 1Ω is available

**Soldering Condition**

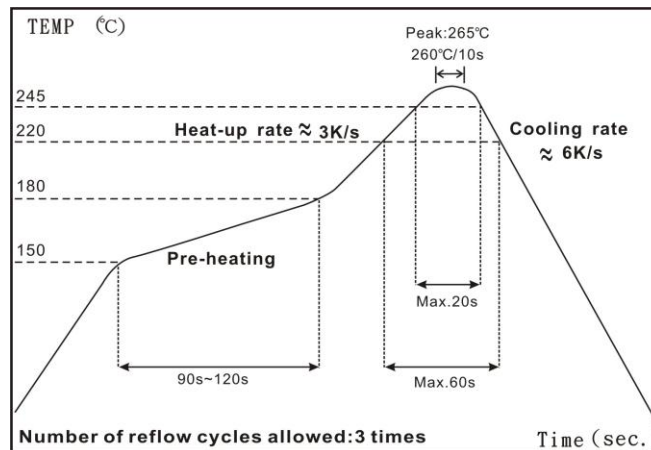

IR Reflow Soldering

- (1) Time of IR reflow soldering at maximum temperature point 260°C : 10s
- (2) Time of soldering iron at maximum temperature point 410°C : 5s

**■ Environmental Characteristics**

Item	Requirement	Test Method
Temperature Coefficient of Resistance (T.C.R.)	As Spec.	<b>JIS-C-5201-1 4.8</b> <b>IEC 60115-1 4.8</b> Referenced to 25°C, ΔR taken at +105°C
Short Time Overload	ΔR±0.3%	<b>JIS-C-5201-1 4.13</b> <b>IEC 60115-1 4.13</b> 2 times rated power with applied voltage not to exceed 1.5 times maximum continuous operating voltage for 5 seconds
Load Life	ΔR±1.0%	<b>JIS-C-5201-1 4.25</b> <b>IEC 60115-1 4.25</b> 2,000 hours at rated power
High Temperature Exposure	ΔR±0.25%	<b>MIL-STD-202 method 108</b> at +175°C for 1000 hrs. Unpowered.
Temperature Cycling	ΔR±0.3%	<b>JESD22 Method JA-104</b> -55°C~+175°C, 1000 cycles
Damp Heat with Load	ΔR±0.5%	<b>JIS-C-5201-1 4.24</b> <b>IEC 60115-1 4.24</b> 40±2°C, 90~95% R.H., RCWV for 1000 hrs with 1.5 hrs "ON" and 0.5 hr "OFF"
Vibration, High Frequency	ΔR±0.2%	<b>MIL-STD-202 Method 204</b> 5 g's for 20 min., 12 cycles each of 3 orientations, 10-2000 Hz
Resistance to Soldering Heat	ΔR±0.5%	<b>JIS-C-5201-1 4.18</b> <b>IEC 60115-1 4.18</b> 260±5°C for 10 seconds
Solderability	90% min. coverage	<b>J-STD-002</b> 245±5°C for 3 seconds
Terminal Strength	No broken	<b>AEC-Q200-006</b> Force of 1.8kg for 60 seconds.

- Lead Material: Tinned Copper
- Maximum Torque: 0.9 N-m
- When in Free Air at 25°C, the STR35 is Rated for 2.50W
- The Case Temperature is to be used for the Definition of the Applied Power Limit
- RCWV(Rated Continuous Working Voltage)= $\sqrt{P \cdot R}$  or Max. Operating Voltage whichever is lower.

**■Packaging**

Reel Specifications & Packaging Quantity

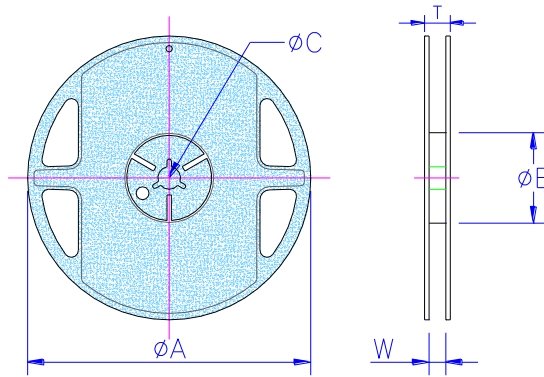

Type	Packaging Quantity	Tape Width	Reel Diameter	ΦA (mm)	ΦB (mm)	ΦC (mm)	W (mm)	T (mm)
STR35	500 pcs	24mm	13 inch	330±1.0	100±0.5	13.5±0.3	25.4±0.5	30.0±0.5

Embossed Plastic Tape Specifications

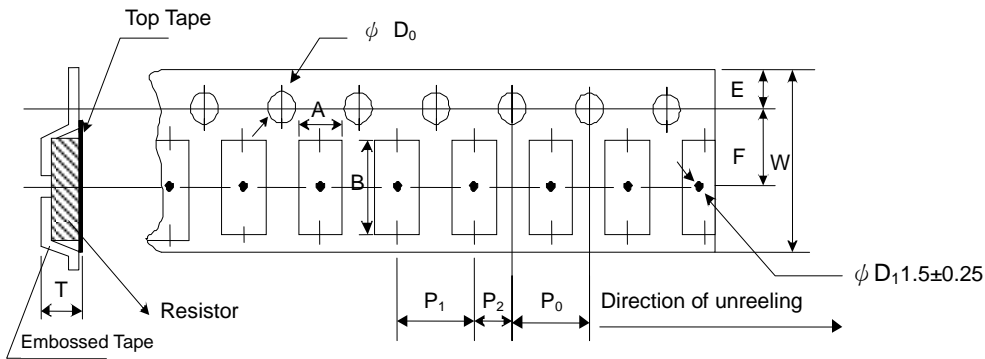

Type	A (mm)	B (mm)	W (mm)	E (mm)	F (mm)	P <sub>0</sub> (mm)	P <sub>1</sub> (mm)	P <sub>2</sub> (mm)	ΦD <sub>0</sub> (mm)	T (mm)
STR35	10.80±0.10	16.13±0.10	24.0±0.30	1.75±0.1	11.5±0.1	4.0±0.1	16.0±0.1	2.0±0.1	1.55±0.05	5.25±0.20

**REVISION HISTORY**

REVISION	DATE	CHANGE NOTIFICATION	DESCRIPTION
Version A	Jun 03,2014	-	- First issue of this specification
Version A1	Apr 30,2015	-	- Increase Tube Package Code
Version A2	Jul 15,2016	-	- Resistance range 1 $\Omega$ -2.7 $\Omega$ increase TCR100 Specifications - Adjust the resistance range